

典型性能 Features

- ◆ 30~50 瓦功率输出 (30~50 Watts of Output Power)
- ◆ 宽电压输入 (Wide Range Input)
- ◆ 长期短路保护, 自恢复 (Short Circuit Protection, Automatic Recovery)
- ◆ 小型化封装 (Small Package)

电气特性 Electrical Specifications

输入特性 Input	Min	Type	Max	Notes
输入电压范围 Input Voltage Range	165Vac	220Vac	265Vac	
	85Vac	220Vac	265Vac	输入电压宽范围, 尾缀加W
输入频率 Input Frequency	45Hz	50/60Hz	65Hz	
输出特性 Output	Min	Type	Max	Notes
输出电压精度 Set point Accuracy	±1%		±3%	Vo1
			±4%	Vo2
源效应 Line Regulation			±0.2% ±1.5%	Vo1 Vo2
负载效应 Load Regulation			±0.5% ±4.0%	Vo1 Vo2
输出电压调节 TRIM Range			±10%	Vo1/Vo2
纹波噪声 (注1) Ripple and Noise			50mV 100mV 200mV	Vo≤5V Other Vo≥36V
动态响应 Dynamic Response		±4%Vo Pk deviation 400μS settling time		50~75% Load 50~25% Load
温度系数 Temperature Regulation		±0.2%/°C		
短路保护 Short-Circuit Protection	长期短路自恢复 Continuous, Automatic Recovery			
综合特性 General	Min	Type	Max	Notes
隔离电压 Isolation Voltage			1500Vac	输入与输出 Input-Output
			1500Vac	输入与壳 Input-Case
			500Vac	输出与壳 Output-Case
开关频率 Switching Frequency	50KHz		150KHz	
平均故障间隔时间 MTBF		3×10 ⁵ Hrs		Mil HDBK 217F Tc=25°C
工作壳温 (注3) Case Temperature	工业级	-40°C	+85°C	
	AD、AG 级	-40°C	+90°C	

储存温度 Storage Temperature	-45℃		+105℃	
相对湿度 Relative Humidity	10%		90%	
管脚焊接温度 Pin Solder Temperature			250℃	Wave Solder <10S
手工焊接时间 Hand Soldering Time			5S	Iron Temperature 425 °C
传导（注4） Conducted Emission	GB9254/CISPR22/EN55022 Class B（推荐电路见图）			
静电放电 Electrostatic Discharge	GB17626/EN61000-4-2 Contact ±4KV			
浪涌抗扰度 Surge Immunity	GB17626/EN61000-4-5 ±2KV（推荐电路见图） perf. Criteria A			
脉冲群抗扰度 Electrical Fast Transient	GB17626/EN61000-4-4 ±4KV（推荐电路见图） perf. Criteria A			

注 1：纹波噪声采用 20MHz 带宽、平行线法测试；

注 2：交流电压测试漏电流为 5mA，直流电压测试漏电流为 0.5mA；

注 3：若符合相关行业 EMI 标准，需增加外围推荐电路或者滤波器；

产品型号列表 Product Model List

型号 Models	输入电压 范围 Input Voltage Range	输出电压 (Vdc) Output Voltage	输出电流 (A) Output Current	纹波噪声 (mv) Ripple and noise	典型效率 Efficiency	容性负载 (μF) Max.Capacitor Load
WAN30S5	165-265Vac	5.05	6	50	80%	4700
WAN30S9	165-265Vac	9	3.3	100	81%	1000
WAN30S12	165-265Vac	12	2.5	100	82%	1000
WAN30S15	165-265Vac	15	2	100	82%	1000
WAN30S18	165-265Vac	18	1.67	100	82%	1000
WAN30S24	165-265Vac	24	1.25	100	83%	470
WAN30S28	165-265Vac	28	1.07	100	83%	470
WAN30S36	165-265Vac	36	0.83	200	84%	220
WAN30S48	165-265Vac	48	0.63	200	85%	220
WAN30D5	165-265Vac	+5.05/-5.05	+3/-3	50/50	80%	2200/2200
WAN30D9	165-265Vac	+9/-9	+1.67/-1.67	100/100	81%	1000/1000
WAN30D12	165-265Vac	+12/-12	+1.25/-1.25	100/100	82%	1000/1000
WAN30D15	165-265Vac	+15/-15	+1/-1	100/100	82%	1000/1000
WAN30D18	165-265Vac	+18/-18	+0.83/-0.83	100/100	82%	470/470
WAN30D24	165-265Vac	+24/-24	+0.63/-0.63	100/100	83%	470/470
WAN30D28	165-265Vac	+28/-28	+0.54/-0.54	100/100	83%	470/470
WAW30S5	85-265Vac	5.05	6	50	80%	4700
WAW30S9	85-265Vac	9	3.3	100	81%	1000
WAW30S12	85-265Vac	12	2.5	100	82%	1000
WAW30S15	85-265Vac	15	2	100	82%	1000
WAW30S18	85-265Vac	18	1.67	100	82%	1000
WAW30S24	85-265Vac	24	1.25	100	83%	470
WAW30S28	85-265Vac	28	1.07	100	83%	470
WAW30S36	85-265Vac	36	0.83	200	84%	220
WAW30S48	85-265Vac	48	0.63	200	85%	220

WAW30D5	85-265Vac	+5.05/-5.05	+3/-3	50/50	80%	2200/2200
WAW30D9	85-265Vac	+9/-9	+1.67/-1.67	100/100	81%	1000/1000
WAW30D12	85-265Vac	+12/-12	+1.25/-1.25	100/100	82%	1000/1000
WAW30D15	85-265Vac	+15/-15	+1/-1	100/100	82%	1000/1000
WAW30D18	85-265Vac	+18/-18	+0.83/-0.83	100/100	82%	470/470
WAW30D24	85-265Vac	+24/-24	+0.63/-0.63	100/100	83%	470/470
WAW30D28	85-265Vac	+28/-28	+0.54/-0.54	100/100	83%	470/470
WAN50S5	165-265Vac	5.05	10	50	80%	4700
WAN50S9	165-265Vac	9	5.56	100	81%	1000
WAN50S12	165-265Vac	12	4.17	100	82%	1000
WAN50S15	165-265Vac	15	3.33	100	82%	1000
WAN50S18	165-265Vac	18	2.78	100	82%	1000
WAN50S24	165-265Vac	24	2.08	100	83%	470
WAN50S28	165-265Vac	28	1.78	100	83%	470
WAN50S36	165-265Vac	36	1.39	200	84%	220
WAN50S48	165-265Vac	48	1.04	200	85%	220
WAN50D5	165-265Vac	+5.05/-5.05	+5/-5	50/50	80%	2200/2200
WAN50D9	165-265Vac	+9/-9	+2.78/-2.78	100/100	81%	1000/1000
WAN50D12	165-265Vac	+12/-12	+2.08/-2.08	100/100	82%	1000/1000
WAN50D15	165-265Vac	+15/-15	+1.67/-1.67	100/100	82%	1000/1000
WAN50D18	165-265Vac	+18/-18	+1.38/-1.38	100/100	82%	470/470
WAN50D24	165-265Vac	+24/-24	+1.04/-1.04	100/100	83%	470/470
WAN50D28	165-265Vac	+28/-28	+0.89/-0.89	100/100	83%	470/470
WAW50S5	85-265Vac	5.05	10	50	80%	4700
WAW50S9	85-265Vac	9	5.56	100	81%	1000
WAW50S12	85-265Vac	12	4.17	100	82%	1000
WAW50S15	85-265Vac	15	3.33	100	82%	1000
WAW50S18	85-265Vac	18	2.78	100	82%	1000
WAW50S24	85-265Vac	24	2.08	100	83%	470
WAW50S28	85-265Vac	28	1.78	100	83%	470

WAW50S36	85-265Vac	36	1.39	200	84%	220
WAW50S48	85-265Vac	48	1.04	200	85%	220
WAW50D5	85-265Vac	+5.05/-5.05	+5/-5	50/50	80%	2200/2200
WAW50D9	85-265Vac	+9/-9	+2.78/-2.78	100/100	81%	1000/1000
WAW50D12	85-265Vac	+12/-12	+2.08/-2.08	100/100	82%	1000/1000
WAW50D15	85-265Vac	+15/-15	+1.67/-1.67	100/100	82%	1000/1000
WAW50D18	85-265Vac	+18/-18	+1.39/-1.39	100/100	82%	470/470
WAW50D24	85-265Vac	+24/-24	+1.04/-1.04	100/100	83%	470/470
WAW50D28	85-265Vac	+28/-28	+0.89/-0.89	100/100	83%	470/470

注 5: 我公司该系列产品按照输出电压大小进行分类; 可参考“机械图及管脚说明”来确定外壳、管脚定义和产品名称; 以上表格中仅列出典型型号, 我公司可根据客户需求信息 (包括功率、输入电压、输出电压、负载特性等) 来单独设计。

电磁兼容应用 (EMC)

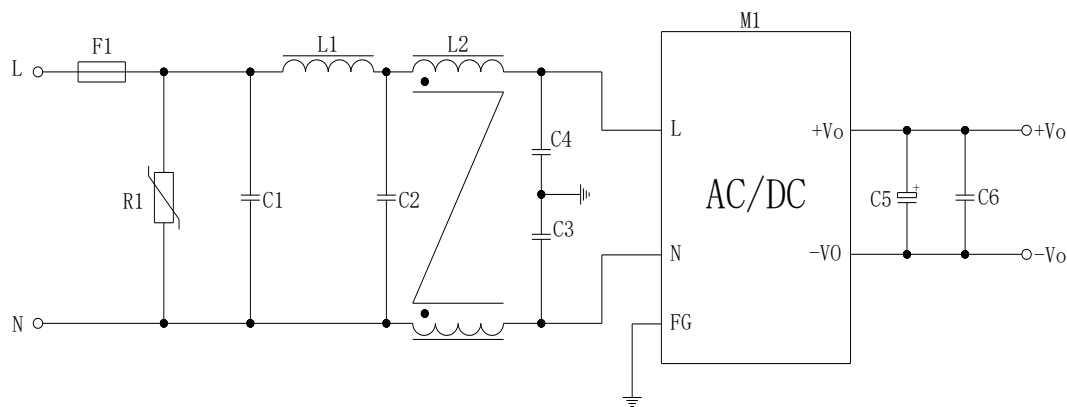

型号	输出电压 5V	输出电压 9V/12V/15V	输出电压 18V/24V
F1 (保险丝)	2~3A 慢熔		
R1/ (压敏电阻)	471KD14 或 511KD14		
C1/C2 (X 电容)	0.47μF/275Vac		
C3/C4 (Y 电容)	2.2nF/250Vac		
L1 (差模电感)	200~300μH		
L2 (共模电感)	10mH		
C5 (电解电容)	470μF/16V	220μF/25V	100μF/35V
C6 (陶瓷电容)	1μF/50V		

输出调节应用 (TRIM Function)

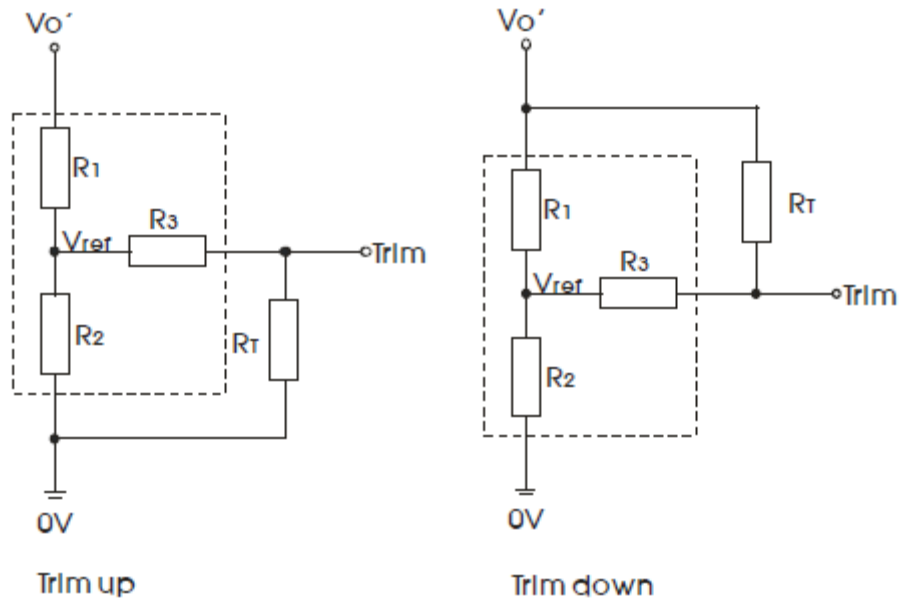

$$up : R_T = \frac{TR_2}{R_2 - T} - R_3 \quad T = \frac{V_{ref}}{V_{o'} - V_{ref}} \cdot R_1$$

$$down : R_T = \frac{TR_1}{R_1 - T} - R_3 \quad T = \frac{V_{o'} - V_{ref}}{V_{ref}} \cdot R_2$$

Vout (V)	R1 (KΩ)	R2 (KΩ)	R3 (KΩ)	Vref (V)
3.3	3.32	2.0	8.2	1.24
5	2.55	2.49	8.2	2.5
9	6.49	2.49	10	2.5
12	9.53	2.49	12	2.5
15	12.5	2.49	15	2.5
24	21.5	2.49	20	2.5
28	25.5	2.49	20	2.5
36	33.5	2.49	20	2.5
48	45.3	2.49	20	2.5

机械图及管脚说明 (Mechanical Chart、Pins) (Unit: mm/ inch)

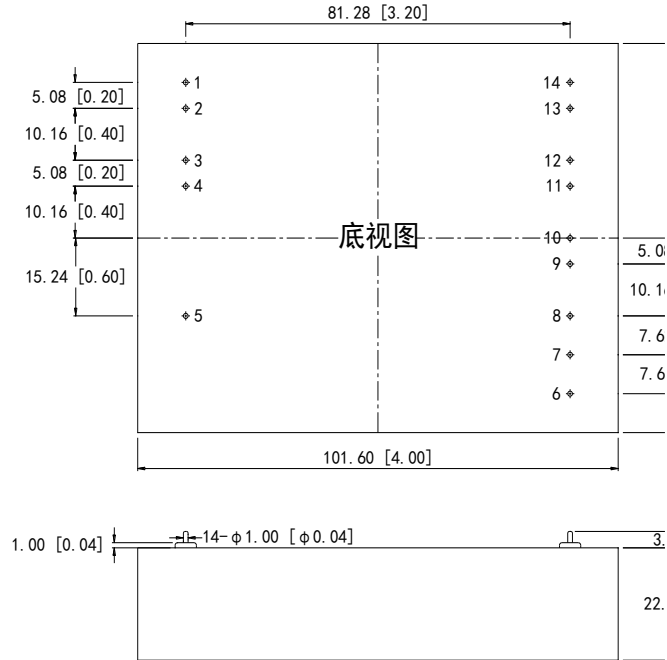

30W 标准型

1) 单路输出电源管脚定义 (如 WAN30S12):

项目	输入端			输出端				
管脚	1	2	3	4	5	6	7	8
定义	L	N	FG	Trim	+Vo	-Vo	NC	NC
说明	火线	零线	地线	输出电压 可调	输出正	输出负	无连接空管脚	

2) 双路对称输出电源管脚定义 (如 WAW30D15):

项目	输入端			输出端				
管脚	1	2	3	4	5	6	7	8
定义	L	N	FG	Trim	+Vo1	COM	-Vo2	-Vo2
说明	火线	零线	地线	输出电压 可调	一路 输出正	输出 公共地	二路输出负	

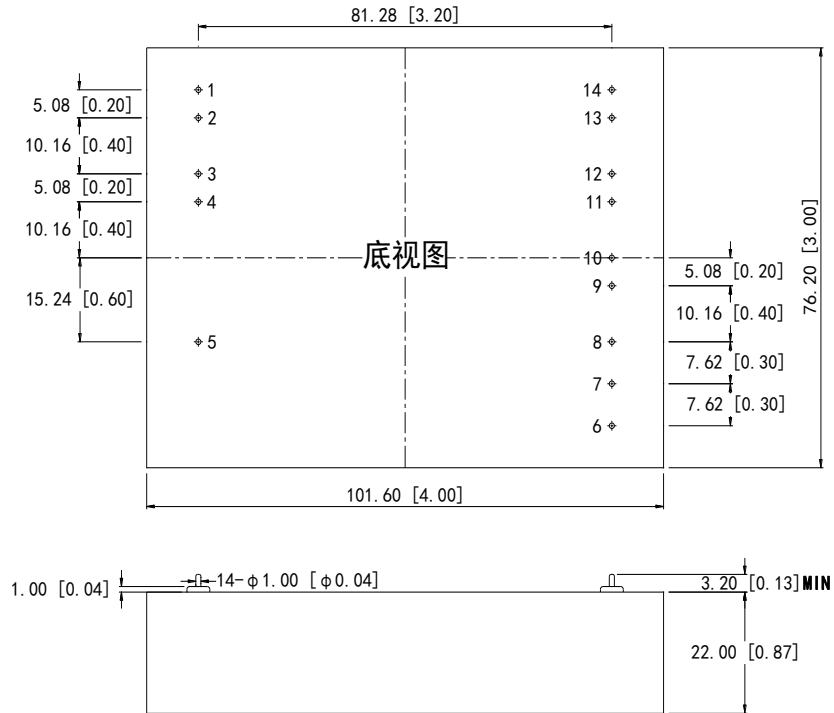

50W 标准型

1) 单路输出电源管脚定义 (如 WAN50S12):

项目	输入端			输出端					
	1/2	3/4	5	6	7	8	9/10	11/12	13/14
管脚	L	N	FG	-S	Trim	+S	NC	-Vo	+Vo
说明	火线	零线	地线	负远传	输出电压可调	正远传	无连接空管脚	输出负	输出正

2) 双路对称输出电源管脚定义 (如 WAW50D15):

项目	输入端			输出端					
	1/2	3/4	5	6	7	8	9/10	11/12	13/14
管脚	L	N	FG	-S	Trim	+S	-Vo2	COM	+Vo1
说明	火线	零线	地线	负远传	输出电压可调	正远传	二路输出负	输出公共地	一路输出正

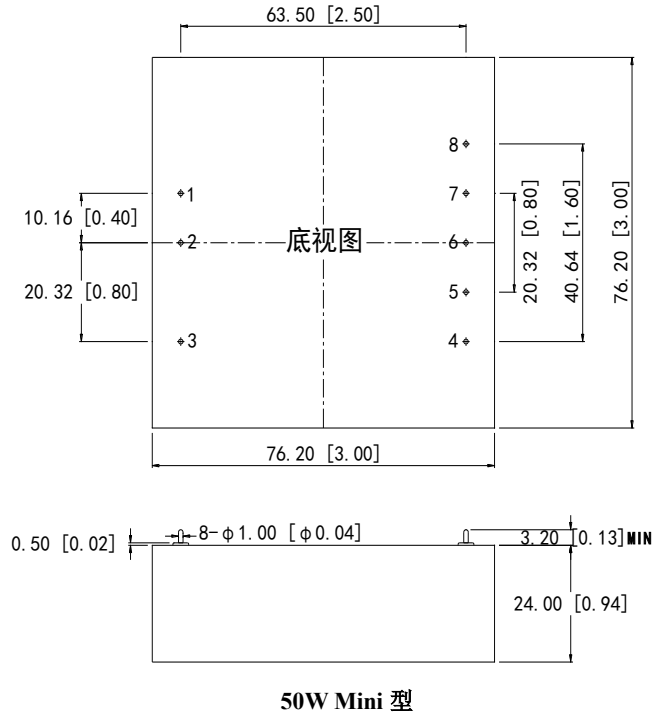

3) Mini 型外壳单路输出电源管脚定义 (如 WAN50S12M) :

项目	输入端			输出端				
	1	2	3	4	5	6	7	8
管脚	1	2	3	4	5	6	7	8
定义	L	N	FG	Trim	+Vo	-Vo	NC	NC
说明	火线	零线	地线	输出电压 可调	输出正	输出负	无连接空管脚	

注 6: 安装定位尺寸公差按 GB/T1804-2000 F 级标准, 外型尺寸公差按 GB/T1804-2000 C 级标准;